



ELPRESS TUBE TERMINAL AND THROUGH CONNECTORS of type KR/KRF/KSF for flexible and stranded Cu-conductors.

Approvals

UL, file no. E205350.

DNV, certificate no. E-7619

SP, ISO14001:2004, certificate no. 3695M

BSI, ISO9001:2001, certificate no. FM20987



Certificate No. FM20987





TABLE OF CONTENTS

ELPRESS TUBE TERMINALS AND THROUGH CONNECTORS	2
Tube terminals 0.75 – 800 mm ²	3
Tube terminals with two stud holes, 70 - 400 mm ² , KRF	6
Tube terminals 45°, 10 - 150 mm ² , KRF.....	7
Tube terminals 90°, 10 - 150 mm ² , KRF.....	9
Through connectors 0.75 - 800 mm ² , KS/KSF.....	11
Tube terminals with small palm type KRF-SP 240 mm ²	12
PACKAGING	14
MARKING	14
CRIMPING AND CRIMPING TOOLS.....	15
RECOMMENDATIONS FOR BOLT CONNECTIONS	16
Approvals.....	16
Tests.....	16
CONTACT ELPRESS	16



Tube terminals 0.75 – 800 mm²

Data: electrolytic copper, annealed, tin plated, cable inspection hole, for flexible and stranded Cu-conductors



Marking example KRF: 70 10F (Elpress logotype included)

F = type KRF

70 = mm² 10 = palm hole for M10



mm ²	AWG	Cat. no. mm ² – bolt hole M	Bolt	mm W	d	N	N ₁	L	Pcs/ pack	Strip Min	Torque Nm	Tool/die no.
0,75	(22)-18	KR 0,75-3*	M3	6,0	1,3	3,2	3,8	16	100	7,5	-	KB0325
0,75	(22)-18	KR0,75-4*	M4	6,0	1,3	3,2	3,8	16	100	7,5	-	“
1,5	(18)-16	KR 1,5-3*	M3	6,5	1,8	3,4	3,6	16	100	7,5	-	“
1,5	(18)-16	KR 1,5-4*	M4	6,5	1,8	4,2	4,3	17	100	7,5	-	“
1,5	(18)-16	KR 1,5-5*	M5	7,5	1,8	4,8	4,7	18	100	7,5	5	“
2,5	(16)-14	KR 2,5-3*	M3	7,5	2,3	3,5	4,1	17	100	7,0	-	“
2,5	(16)-14	KR 2,5-4*	M4	7,5	2,3	4,2	4,1	18	100	7,0	-	“
2,5	(16)-14	KR 2,5-5*	M5	8,5	2,3	4,8	4,8	19	100	7,0	5	“
2,5	(16)-14	KR 2,5-6*	M6	8,5	2,3	5,1	4,9	19	100	7,0	9	“
4	12	KR 4-4	M4	8,5	3,0	4,2	5,8	21	100	8,5	-	WB4099
4	12	KR 4-5	M5	9,0	3,0	4,8	5,2	22	100	8,5	5	“
4	12	KR 4-6	M6	10,0	3,0	5,0	7,0	23	100	8,5	9	“
6	10	KR 6-4	M4	9,5	4,0	4,0	7,0	22	100	8,5	-	“
6	10	KR 6-5	M5	9,5	4,0	5,0	6,0	22	100	8,5	5	“
6	10	KR 6-6	M6	10,0	4,0	5,5	6,5	23	100	8,5	9	“
6	10	KR 6-8	M8	13,5	4,0	7,0	10,0	30	100	8,5	21	“
10	8	KR 10-5	M5	11,5	5,0	6,0	7,0	29	100	11,0	5	“
10	8	KR 10-6	M6	11,5	5,0	6,0	7,0	29	100	11,0	9	“
10	8	KR 10-8	M8	13,5	5,0	7,0	9,0	33	100	11,0	21	“
10	8	KR 10-10	M10	16,0	5,0	8,0	10,0	34	100	11,0	41	“
10	8	KR 10-12	M12	19,0	5,0	10,0	14,0	41	100	11,0	70	“

* no inspection hole.



mm ²	AWG/MCM	Cat. no. mm ² –bolt hole M	Bolt	mm W	d	N	N ₁	L	Pcs/ pack	Strip min	Torque Nm	Die no.
AWG												
16	6	KRF16-5	M5	13	6,0	8,0	9,0	34	100	12	5	9
16	6	KRF 16-6	M6	13	6,0	8,0	9,0	34	100	12	9	9
16	6	KRF 16-8	M8	13	6,0	8,0	9,0	34	100	12	21	9
16	6	KRF 16-10	M10	16	6,0	10,0	11,0	38	100	12	41	9
16	6	KRF 16-12	M12	22	6,0	12,0	13,0	47	100	15	70	9
25	4	KRF25-5	M5	16	8,0	8,0	10,0	39	100	14	5	11
25	4	KRF 25-6	M6	16	8,0	8,0	10,0	39	100	14	9	11
25	4	KRF 25-8	M8	16	8,0	8,0	10,0	39	100	14	21	11
25	4	KRF 25-10	M10	17	8,0	10,0	11,0	42	100	14	41	11
25	4	KRF 25-12	M12	22	8,0	12,0	13,0	47	100	15	70	11
35	2	KRF 35-6	M6	18	9,0	10,0	11,0	47	100	16	9	13
35	2	KRF 35-8	M8	18	9,0	10,0	11,0	47	100	16	21	13
35	2	KRF 35-10	M10	18	9,0	10,0	11,0	47	100	16	41	13
35	2	KRF 35-12	M12	22	9,0	12,0	14,0	52	100	16	70	13
50	1/0	KRF 50-6	M6	21	11,0	11,0	12,0	50	100	19	9	14,5
50	1/0	KRF 50-8	M8	21	11,0	11,0	12,0	50	100	19	21	14,5
50	1/0	KRF 50-10	M10	21	11,0	11,0	12,0	50	100	19	41	14,5
50	1/0	KRF 50-12	M12	21	11,0	12,0	14,0	53	100	19	70	14,5
50	1/0	KRF 50-16	M16	27	11,0	15,0	17,0	59	100	19	170	14,5
70	2/0	KRF 70-6	M6	25	13,0	11,0	12,0	55	50	22	9	17
70	2/0	KRF 70-8	M8	25	13,0	11,0	12,0	55	50	22	21	17
70	2/0	KRF 70-10	M10	25	13,0	11,0	12,0	55	50	22	41	17
70	2/0	KRF 70-12	M12	25	13,0	12,0	14,0	58	50	22	70	17
70	2/0	KRF 70-16	M16	28	13,0	15,0	17,0	64	50	22	170	17
95	4/0	KRF 95-8	M8	29	15,0	15,0	17,0	69	50	25	21	20
95	4/0	KRF 95-10	M10	29	15,0	15,0	17,0	69	50	25	41	20
95	4/0	KRF 95-12	M12	29	15,0	15,0	17,0	69	50	25	70	20
95	4/0	KRF 95-16	M16	29	15,0	15,0	17,0	69	50	25	170	20
	MCM											
120	250	KRF 120-10	M10	32	17,0	15,0	17,0	73	25	27	41	22
120	250	KRF 120-12	M12	32	17,0	15,0	17,0	73	25	27	70	22
120	250	KRF 120-16	M16	32	17,0	15,0	17,0	73	25	27	170	22
150	300	KRF 150-10	M10	36	19,0	15,0	17,0	80	25	32	41	25



mm ²	AWG/MCM	Cat. no. mm ² –bolt hole M	Bolt	mm W	d	N	N _i	L	Pcs/ pack	Strip min	Torque Nm	Die no.
150	300	KRF 150-12	M12	36	19,0	15,0	17,0	80	25	32	70	25
150	300	KRF 150-16	M16	36	19,0	15,0	17,0	80	25	32	170	25
150	300	KRF 150-20	M20	36	19,0	19,0	20,0	87	25	32	340	25
185	350	KRF 185-10	M10	39	21,0	15,0	17,0	86	20	37	41	27
185	350	KRF 185-12	M12	39	21,0	15,0	17,0	86	20	37	70	27
185	350	KRF 185-16	M16	39	21,0	15,0	17,0	86	20	37	170	27
185	350	KRF 185-20	M20	39	21,0	19,0	20,0	93	20	37	340	27
240	500	KRF 240A-10	M10	42	22,5	19,0	20,0	96	10	37	41	30
240	500	KRF 240A-12	M12	42	22,5	19,0	20,0	96	10	37	70	30
240	500	KRF 240A-16	M16	42	22,5	19,0	20,0	96	10	37	170	30
240	500	KRF 240A-20	M20	42	22,5	19,0	20,0	96	10	37	340	30
300	600	KRF 300A-10	M10	45	24,5	22,0	32,0	116	10	44	41	32
300	600	KRF 300A-12	M12	45	24,5	22,0	32,0	116	10	44	70	32
300	600	KRF 300A-16	M16	45	24,5	22,0	32,0	116	10	44	170	32
300	600	KRF 300A-20	M20	45	24,5	22,0	32,0	116	10	44	340	32
300	600	KRF 300A-24	M24	45	24,5	22,0	32,0	116	10	44	610	32
400	750	KRF 400A-00	-	56	30,0	-	-	125	10	52	-	38
400	750	KRF 400A-12	M12	56	30,0	22,0	33,0	125	10	52	70	38
400	750	KRF 400A-16	M16	56	30,0	22,0	33,0	125	10	52	170	38
400	750	KRF 400A-20	M20	56	30,0	22,0	33,0	125	10	52	340	38
400	750	KRF 400A-24	M24	56	30,0	22,0	33,0	125	10	52	610	38
500	1000	KRF 500-00	-	61	33,0	70**		160	5	68	-	42
500	1000	KRF 500-16	M16	61	33,0	25,0	35,0	150	5	68	170	42
500	1000	KRF 500-20	M20	61	33,0	25,0	35,0	150	5	68	340	42
500	1000	KRF 500-24	M24	61	33,0	25,0	35,0	150	5	68	610	42

** total palm length



Tube terminals with two stud holes, 70 - 400 mm², KRF

Data: electrolytic copper, annealed, tin plated, cable inspection hole, for flexible and stranded Cu-conductors.



Marking example KRF: 70 10F (Elpress logotype  included)

F = type KRF

70 = mm² 10 = palm hole for M10



mm ²	AWG/MCM	Cat no, mm ² , Bolt, cc-measure	Bolt	mm W	d	N	N ₁	L	Pcs/pack	Strip Min	Torque Nm	Die no.
70	2/0	KRF 70-12X2-40	M12	25	13,0	12	18	103	25	22	70	17
95	4/0	KRF 95-12X2-40	M12	29	15,0	12	18	109	25	25	70	20
120	250	KRF 120-12X2-40	M12	32	17,0	12	19	113	25	27	70	22
150	300	KRF 150-12X2-40	M12	36	19,0	12	19	120	20	32	70	25
185	350	KRF 185-12X2-40	M12	39	21,0	12	20	126	20	37	70	27
240	500	KRF 240A-12X2-40	M12	42	22,5	12	21	130	10	37	70	30
300	600	KRF 300A-12X2-40	M12	45	24,5	12	22	136	10	44	70	32
400	750	KRF 400A-12X2-40	M12	56	30,0	12	23	145	10	52	70	38

More two-hole tube terminals are available upon request!



Tube terminals 45°, 10 - 150 mm², KRF

Data: electrolytic copper, annealed, tin plated, cable inspection hole, for flexible and stranded Cu-conductors.



Marking example KRF: 70 10F (Elpress logotype  included)

F = type KRF

70 = mm²

10 = palm hole for M10



mm ²	AWG/MCM	Cat no., mm ² , Bolt, 45°	Bolt	mm W	d	N	N _i	A	Pcs/ pack	Strip Min	Torque Nm	Die no.
	AWG											
10	8	KR 10-5-45GR	M5	13,0	5,0	6,5	11,0	19	100	15	5	8
10	8	KR 10-6-45GR	M6	13,0	5,0	6,5	11,5	19	100	15	9	8
10	8	KR 10-8-45GR	M8	13,5	5,0	8,5	12,0	19	100	15	21	8
10	8	KR 10-10-45GR	M10	13,5	5,0	11,5	13,5	19	100	15	41	8
16	6	KRF 16-5-45GR	M5	13,0	6,0	6,5	11,0	23	100	18	5	9
16	6	KRF 16-6-45GR	M6	13,0	6,0	6,5	11,5	23	100	18	9	9
16	6	KRF 16-8-45GR	M8	13,5	6,0	8,5	12,0	23	100	18	21	9
16	6	KRF 16-10-45GR	M10	13,0	6,0	11,5	13,5	23	100	18	41	9
16	6	KRF 16-12-45GR	M12	13,0	6,0	12,5	18,5	23	100	18	70	9
25	4	KRF 25-6-45GR	M6	17,0	8,0	6,5	11,5	24	100	19	9	11
25	4	KRF 25-8-45GR	M8	17,0	8,0	8,5	12,0	24	100	19	21	11
25	4	KRF 25-10-45GR	M10	17,0	8,0	11,5	13,5	24	100	19	41	11
25	4	KRF 25-12-45GR	M12	17,0	8,0	12,5	18,5	24	100	19	70	11
35	2	KRF 35-6-45GR	M6	18,0	9,0	6,5	11,5	30	100	23	9	13
35	2	KRF 35-8-45GR	M8	18,0	9,0	8,5	12,0	30	100	23	21	13
35	2	KRF 35-10-45GR	M10	18,0	9,0	11,5	13,5	30	100	23	41	13
35	2	KRF 35-12-45GR	M12	18,0	9,0	12,5	18,5	30	100	23	70	13
50	1/0	KRF 50-6-45GR	M6	21,0	11,0	6,5	14,5	31	100	24	9	14,5
50	1/0	KRF 50-8-45GR	M8	21,0	11,0	8,5	17,5	31	100	24	21	14,5
50	1/0	KRF 50-10-45GR	M10	21,0	11,0	11,5	18,5	31	100	24	41	14,5
50	1/0	KRF 50-12-45GR	M12	21,0	11,0	12,5	19,5	31	100	24	70	14,5
50	1/0	KRF 50-16-45GR	M16	21,0	11,0	15,5	20,5	31	100	24	170	14,5
70	2/0	KRF 70-6-45GR	M6	25,0	13,0	8,5	17,5	35	50	28	9	17
70	2/0	KRF 70-8-45GR	M8	25,0	13,0	8,5	17,5	35	50	28	21	17
70	2/0	KRF 70-10-45GR	M10	25,0	13,0	11,5	18,5	35	50	28	41	17



mm ²	AWG/MCM	Cat no., mm2, Bolt, 45°	Bolt	mm W	d	N	N _i	A	Pcs/ pack	Strip Min	Torque Nm	Die no.
70	2/0	KRF 70-12-45GR	M12	25,0	13,0	12,5	19,5	35	50	28	70	17
70	2/0	KRF 70-16-45GR	M16	25,0	13,0	15,5	20,5	35	50	28	170	17
95	4/0	KRF 95-8-45GR	M8	29,0	15,0	8,5	17,5	40	50	30	21	20
95	4/0	KRF 95-10-45GR	M10	29,0	15,0	11,5	18,5	40	50	30	41	20
95	4/0	KRF 95-12-45GR	M12	29,0	15,0	12,5	19,5	40	50	30	70	20
95	4/0	KRF 95-16-45GR	M16	29,0	15,0	15,5	20,5	40	50	30	170	20
	MCM											
120	250	KRF 120-8-45GR	M8	32,0	17,0	8,5	17,5	43	25	32	21	22
120	250	KRF 120-10-45GR	M10	32,0	17,0	11,5	18,5	43	25	32	41	22
120	250	KRF 120-12-45GR	M12	32,0	17,0	12,5	19,5	43	25	32	70	22
120	250	KRF 120-16-45GR	M16	32,0	17,0	15,5	20,5	43	25	32	170	22
150	300	KRF 150-10-45GR	M10	36,0	19,0	11,5	18,5	49	25	37	41	25
150	300	KRF 150-12-45GR	M12	36,0	19,0	12,5	19,5	49	25	37	70	25
150	300	KRF 150-16-45GR	M16	36,0	19,0	15,5	20,5	49	25	37	170	25
185	350	KRF185-10-45GR	M10	39,0	21,0	11,5	18,5	55	25	42	41	27
185	350	KRF185-12-45GR	M12	39,0	21,0	12,5	19,5	55	25	42	70	27
185	350	KRF185-16-45GR	M16	39,0	21,0	15,5	20,5	55	25	42	170	27
240	500	KRF240A-10-45GR	M10	42,0	22,5	11,5	18,5	57	25	42	41	30
240	500	KRF240A-12-45GR	M12	42,0	22,5	12,5	19,5	57	25	42	70	30
240	500	KRF240A-16-45GR	M16	42,0	22,5	15,5	20,5	57	25	42	170	30



Tube terminals 90°, 10 - 150 mm², KRF

Data: electrolytic copper, annealed, tin plated, cable inspection hole, for flexible and stranded Cu-conductors.



Marking example KRF: 70 10F (Elpress logotype  included)

F = type KRF

70 = mm²

10 = palm hole for M10



mm ²	AWG/MCM	Cat. no., mm ² Bolt, 90°	Bolt	mm W	d	N	N ₁	A	Pcs/ pack	Strip Min	Torque Nm	Die no.
	AWG											
10	8	KR 10-5-90GR	M5	13,0	5,0	6,5	11,0	15	100	13	5	8
10	8	KR 10-6-90GR	M6	13,0	5,0	6,5	11,5	15	100	13	9	8
10	8	KR 10-8-90GR	M8	13,5	5,0	8,5	12,0	15	100	13	21	8
10	8	KR 10-10-90GR	M10	13,5	5,0	11,5	13,5	15	100	13	41	8
16	6	KRF 16-5-90GR	M5	13,0	6,0	6,5	11,0	17	100	14	5	9
16	6	KRF 16-6-90GR	M6	13,0	6,0	6,5	11,5	17	100	14	9	9
16	6	KRF 16-8-90GR	M8	13,5	6,0	8,5	12,0	17	100	14	21	9
16	6	KRF 16-10-90GR	M10	13,5	6,0	11,5	13,5	17	100	14	41	9
16	6	KRF 16-12-90GR	M12	13,5	6,0	12,5	18,5	17	100	14	70	9
25	4	KRF 25-6-90GR	M6	17,0	8,0	6,5	11,5	18,5	100	15	9	11
25	4	KRF 25-8-90GR	M8	17,0	8,0	8,5	12,0	18,5	100	15	21	11
25	4	KRF 25-10-90GR	M10	17,0	8,0	11,5	13,5	18,5	100	15	41	11
25	4	KRF 25-12-90GR	M12	17,0	8,0	12,5	18,5	18,5	100	15	70	11
35	2	KRF 35-6-90GR	M6	18,0	9,0	6,5	11,5	22,5	100	20	9	13
35	2	KRF 35-8-90GR	M8	18,0	9,0	8,5	12,0	22,5	100	20	21	13
35	2	KRF 35-10-90GR	M10	18,0	9,0	11,5	13,5	22,5	100	20	41	13
35	2	KRF 35-12-90GR	M12	18,0	9,0	12,5	18,5	22,5	100	20	70	13
50	1/0	KRF 50-6-90GR	M6	21,0	11,0	6,5	14,5	30,5	100	26	9	14,5
50	1/0	KRF 50-8-90GR	M8	21,0	11,0	8,5	17,5	30,5	100	26	21	14,5
50	1/0	KRF 50-10-90GR	M10	21,0	11,0	11,5	18,5	30,5	100	26	41	14,5
50	1/0	KRF 50-12-90GR	M12	21,0	11,0	12,5	19,5	30,5	100	26	70	14,5
50	1/0	KRF 50-16-90GR	M16	21,0	11,0	15,5	20,5	30,5	100	26	170	14,5
70	2/0	KRF 70-6-90GR	M6	25,0	13,0	8,5	17,5	31,5	50	28	9	17
70	2/0	KRF 70-8-90GR	M8	25,0	13,0	8,5	17,5	31,5	50	28	21	17
70	2/0	KRF 70-10-90GR	M10	25,0	13,0	11,5	18,5	31,5	50	28	41	17



mm ²	AWG/MCM	Cat. no., mm2 Bolt, 90°	Bolt	mm W	d	N	N ₁	A	Pcs/pack	Strip Min	Torque Nm	Die no.
70	2/0	KRF 70-12-90GR	M12	25,0	13,0	12,5	19,5	31,5	50	28	70	17
70	2/0	KRF 70-16-90GR	M16	25,0	13,0	15,5	20,5	31,5	50	28	170	17
95	4/0	KRF 95-8-90GR	M8	29,0	15,0	8,5	17,5	32,5	50	29	21	20
95	4/0	KRF 95-10-90GR	M10	29,0	15,0	11,5	18,5	32,5	50	29	41	20
95	4/0	KRF 95-12-90GR	M12	29,0	15,0	12,5	19,5	32,5	50	29	70	20
95	4/0	KRF 95-16-90GR	M16	29,0	15,0	15,5	20,5	32,5	50	29	170	20
	MCM											
120	250	KR 120-8-90GR	M8	32,0	17,0	8,5	17,5	34,5	25	31	21	22
120	250	KR 120-10-90GR	M10	32,0	17,0	11,5	18,5	34,5	25	31	41	22
120	250	KR 120-12-90GR	M12	32,0	17,0	12,5	19,5	34,5	25	31	70	22
120	250	KR 120-16-90GR	M16	32,0	17,0	15,5	20,5	34,5	25	31	170	22
150	300	KRF 150-10-90GR	M10	36,0	19,0	11,5	18,5	37,5	25	34	41	25
150	300	KRF 150-12-90GR	M12	36,0	19,0	12,5	19,5	37,5	25	34	70	25
150	300	KRF 150-16-90GR	M16	36,0	19,0	15,5	20,5	37,5	25	34	170	25
185	350	KRF185-10-90GR	M10	39,0	21,0	11,5	18,5	42,5	25	38	41	27
185	350	KRF185-12-90GR	M12	39,0	21,0	12,5	19,5	42,5	25	38	70	27
185	350	KRF185-16-90GR	M16	39,0	21,0	15,5	20,5	42,5	25	38	170	27
240	500	KRF240A-10-90GR	M10	42,0	22,5	11,5	18,5	42,5	25	38	41	30
240	500	KRF240A-12-90GR	M12	42,0	22,5	12,5	19,5	42,5	25	38	70	30
240	500	KRF240A-16-90GR	M16	42,0	22,5	15,5	20,5	42,5	25	38	170	30



Through connectors 0.75 - 800 mm², KS/KSF

Data: electrolytic copper, annealed, tin plated, cable inspection hole and cable stop, for flexible and stranded Cu-conductors.



Marking example: 20 95F 111 (earth-sign) Elpress logotype  included

4/0 = AWG F = type KRF

20 = Back nr 95 = mm²

111 = screen mm²



mm ²	AWG/MCM	Cat. no. mm ²	Screen cross section	mm d	D	L	Pcs/ pack	Strip Min	Die No.
	AWG								
0,75	(22)-18	KS 0,75		1,3	2,8	14	100	7	KB0325
1,5	(18)-16	KS 1,5		1,8	3,3	14	100	7	"
2,5	(16)-14	KS 2,5		2,3	4,2	16	100	8	"
4	12	KS4		3,0	5,0	19	100	10	WB4099
6	10	KS6		4,0	6,0	19	100	10	"
10	8	KS10		5,0	8,0	30	100	15	"
16	6	KSF 16	15	6,0	9,0	35	100	18	9
25	4	KSF 25	21-29	8,0	11,0	35	100	18	11
35	2	KSF 35	41	9,0	13,0	35	100	18	13
50	1/0	KSF 50	57	11,0	14,5	45	50	23	14,5
70	2/0	KSF 70	72-88	13,0	17,0	45	50	23	17
95	4/0	KSF 95	111	15,0	20,0	45	50	23	20
	MCM								
120	250	KSF 120		17,0	22,0	55	50	28	22
150	300	KSF 150		19,0	25,0	65	25	33	25
185	350	KSF 185		21,0	27,0	70	25	35	27
240	500	KSF 240A		22,5	29,0	70	25	35	30
300	600	KSF 300A		24,0	31,5	75	10	38	32
400	750	KSF 400A		30,0	38,0	100	10	50	38
500	1000	KSF 500 flexible		33,0	42,0	135	5	67	42



Tube terminals with small palm type KRF-SP 240 mm²

Data: electrolytic copper, annealed, tin plated, cable inspection hole, for flexible and stranded Cu-conductors



Marking example KRF: 70 10F (Elpress logotype  included)

F = type KRF

70 = mm² 10 = palm hole for M10



mm ²	MCM	Cat. no. mm ² –bolt hole	Bolt	mm W	d	N	N _i	L	Pcs/ pack	Strip Min	Torque Nm	Die no.
240	500	KRF240A-10-SP	M10	38	22,5	19	20	96	10	37	41	30
240	500	KRF240A-12-SP	M12	38	22,5	19	20	96	10	37	70	30
240	500	KRF240A-16-SP	M16	38	22,5	19	20	96	10	37	170	30
240	500	KRF240A-20-SP	M20	38	22,5	19	20	96	10	37	340	30

Data: electrolytic copper, annealed, tin plated, cable inspection hole, for flexible and stranded Cu-conductors

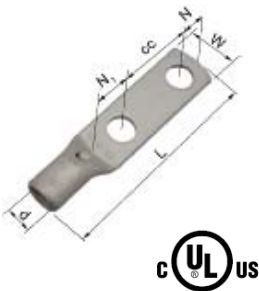

Marking example KRF: 70 10F (Elpress logotype  included)

F = type KRF

70 = mm² 10 = palm hole for M10



mm ²	MCM	Cat no, mm ² , Bolt, cc-measure	Bolt	mm W	d	N	N _i	L	Pcs/ pack	Strip Min	Torque Nm	Die no.
240	500	KRF 240A-12X2-40SP	M12	38	22,5	12	21	130	10	37	70	30
240	500	KRF 240A-16X2-40SP	M16	38	22,5	15	20	132	10	37	170	30



Data: electrolytic copper, annealed, tin plated, cable inspection hole, for flexible and stranded Cu-conductors



Marking example KRF: 70 10F (Elpress logotype  included)

F = type KRF

70 = mm² 10 = palm hole for M10

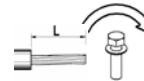

mm ²	MCM	Cat no., mm ² , Bolt, 45°	Bolt	mm W	d	N	N ₁	A	Pcs/pack	Strip Min	Torque Nm	Die no.
240	500	KRF240A-10-45GR-SP	M10	38	22,5	11,5	18,5	57	25	42	41	30
240	500	KRF240A-12-45GR-SP	M12	38	22,5	12,5	19,5	57	25	42	70	30
240	500	KRF240A-16-45GR-SP	M16	38	22,5	15,5	20,5	57	25	42	170	30

Data: electrolytic copper, annealed, tin plated, cable inspection hole, for flexible and stranded Cu-conductors



Marking example KRF: 70 10F (Elpress logotype  included)

F = type KRF

70 = mm² 10 = palm hole for M10



mm ²	MCM	Cat. no., mm ² Bolt, 90°	Bolt	mm W	d	N	N ₁	A	Pcs/pack	Strip Min	Torque Nm	Die no.
240	500	KRF240A-10-90GR-SP	M10	38	22,5	11,5	18,5	42,5	25	38	41	30
240	500	KRF240A-12-90GR-SP	M12	38	22,5	12,5	19,5	42,5	25	38	70	30
240	500	KRF240A-16-90GR-SP	M16	38	22,5	15,5	20,5	42,5	25	38	170	30



PACKAGING

All KRF/KSF terminals are packaged in carton boxes with an information label as below picture. The information states among other things, quantity, EAN 13 bar code, tool and area size for metric conductors and AWG/MCM size for UL-approved conductors



MARKING

Elpress marking system for Cu-connectors shows logotype, conductor area and id-number for crimp die to be used. This system enables final inspection of proper die use as the die number is automatically imprinted by the die on the crimped barrel.

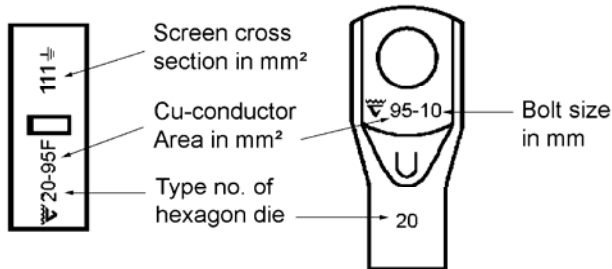

Marking of tube terminals
20 (on the terminal neck)
ID-no. For the hexagonal die
(Elpress logo  95-10F (on the palm)
95 = Cu conductor area, mm ²
10 = hole for screw/bolt M10
F = KRF

Marking of connectors
Elpress logo  20
ID-mo. For the hexagonal die
95F (screen area)
95 = Cu conductor area, mm ²
F = KSF



CRIMPING AND CRIMPING TOOLS

Always use Elpress dies as in the tables above. Number of crimps is depending on which tool system that is used, 3-ton, 6-ton, 13-ton or 25-ton. The column die No. in below table gives the usable die for chosen KRF/KSF terminal.

3-ton system PV350
 6-ton system V600, V611, PV611, T2600
 13-ton system V1300, V1311, PV1300, V1300C, V1311C
 13-ton DUAL DV1300, DV1300C
 25-ton system V250

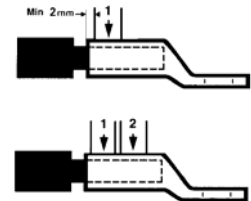

If possible multiple crimps should be positioned with a few mm distance from each other and from the neck end. In some cases however overlapping crimps have to be made for space reasons.

mm	Die No	3-ton system		6-ton system		13-ton system		13-ton DUAL		25-ton system		
		Die	No. of Crimp	Die	No. of Crimp	Die	No. of Crimp	Die	No. of Crimp	Die	No. of Crimp	
10	8	MB8	1	TB8-17	1	B8	1	B8	1	B8	1	
16	9	MB9		TB9-13		B9		13DB9 13DCB9		B9		
25	11	MB11	TB11-14,5	B11		13DB11 13DCB11		B11				
35	13	MB13	TB9-13	B13		13DB13 13DCB13		B13				
50	14,5	MB14,5	TB11-14,5	B14,5		13DB14,5 13DCB14,5		B14,5				
70	17	MB17	3	TB8-17		B17		13DB17 13DCB17		B17		
95	20		2	TB7-20		B20		13DB20 13DCB20		B20		
120	22		3	KB22		B22		13DB22 13DCB22		2		B22
150	25			KB25		B25		13DB25 13DCB25				B25
185	27					13B27 13CB27		13DB27 13DCB27				B27
240	30				13B30 13CB30	13DB30 13DCB30	B30					
300	32				13B32 13CB32	13DB32 13DCB32	B2532					
400	38				13B38	3	B2538	2				
500	42						B2542	3				
630	53						B2553					
800	53						B2553					



RECOMMENDATIONS FOR BOLT CONNECTIONS

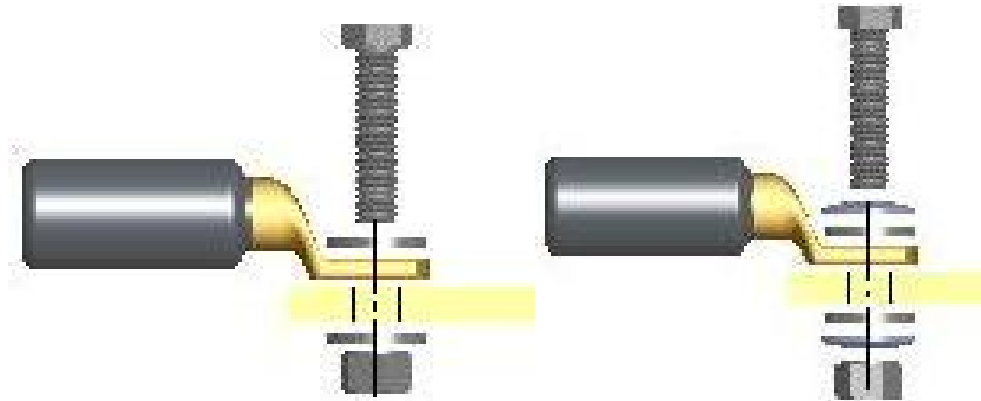

- Always use a torque wrench to be sure that the right torque is achieved
- Always use a flat, thick, hard wascher, hardness min HB200.
- Assembly as in picture above
- Use torque as in tables above.
- For nuts and bolts, electro-plated type, lubricated threads, strength class 8.8, which are used to connect terminals.



For special applications use a spring tension plate DIN 6796, as in picture here and above, together with a flat washer to increase the force.

TESTING AND APPROVALS

Elpress tube terminals and through connectors of type KR/KRF/KSF for flexible and stranded Cu-conductors meet the requirements and has the following approvals.

Approvals

- UL, file no. E205350.
- DNV, certificate no. E-7619
- SP, ISO14001:2004, certificate no. 3695M
- BSI, ISO9001:2001, certificate no. FM20987

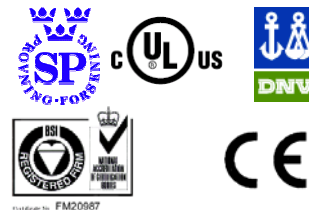

Tests

By crimping Elpress terminals and connectors of type KRF/KSF with Elpress crimping tools, connections are achieved that meet the requirements of IEC 61238:1.

CONTACT ELPRESS

Adress: Elpress AB
P.O. Box 186
SE-87 224 KRAMFORS
SWEDEN

E-mail: sales@elpress.se
Web: www.elpress.net

Tel: +46 612 71 71 00
Fax: +46 612 71 71 51