

Patented

MD I-1, sealing system 25 mm cap

For openings min. Ø 16 mm to max. 32 mm and cables to max Ø 12,5 mm
Art. nr. 280220P

MD I-2, sealing system 50 mm cap

For openings min. Ø 32 mm to max. 60 mm and cables to max Ø 25 mm
Art. nr. 280223P

The MD I duct sealing system has been developed for the sealing of pliable cables which have been bent to a small radius at the point of entry, therefore allowing the cable to continue along the wall to the point where it is required.

The MD I system is equipped with a special and patented fixing anchor for the outside of solid walls (Fig. 1), thus requiring no drilling and installation only takes a few minutes.

In order to avoid water or gas penetration in cavity walls, it would be better to install a cable protection sleeve or tube (Fig. 2) to hold the fixing anchor more securely.

In order to allow the cable to be fed in from above as well as from below, the caps are equipped with 2 filling plugs. This enables installation of the cap in every possible position.

Content of one set type MD I

- Cap with 2 filling plugs and foam gasket
- Twin pack containing expanding polyurethane filler
- Foam block
- Fixing anchor
- Screw type nipple
- Set protective gloves
- Sandpaper
- Installation instruction

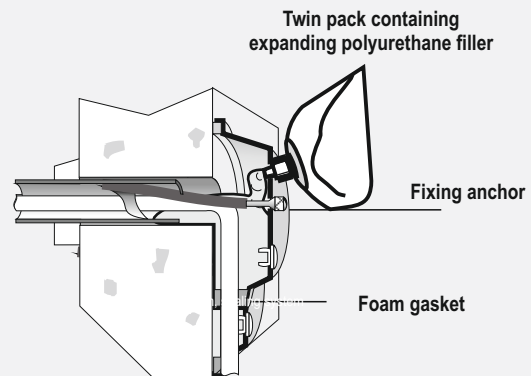

Fig. 1

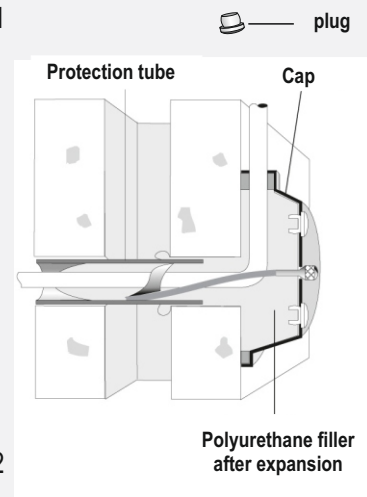

Fig. 2

Gas and watertight

Sealing systems

Subject to change without notice